

IM2 Problem Set 1.12 - Review of 3D Shapes - Surface Area and Volume

<p>BIG PICTURE of this UNIT:</p>	<ul style="list-style-type: none"> ● mastery with linear algebraic skills to be used in our work with coordinate geometry (midpoint, length, slope) ● understanding various geometric properties of quadrilaterals, triangles & circles ● how do you really “prove” that something is “true”? ● introduction to working with 3D shapes
---	--

Part 1 – Review - Basics

1. Find the volume and surface area of the cube where each side is 6 cm in length.
2. Find the volume and surface area of the following red cuboid shown here.
3. Find the volume and surface area of the cylinder whose diameter and height are both 10 cm, rounding your answers to the nearest unit.
4. Find the volume and surface area of the sphere whose radius is 12 cm.

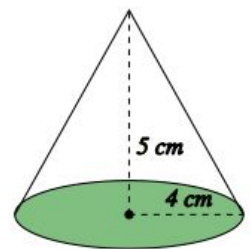
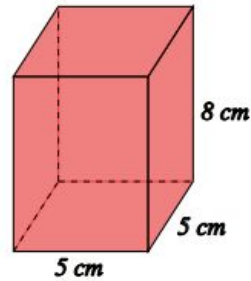

5. Find the volume and surface area of the solid cone shown here, rounding your answers to 3 significant figures.

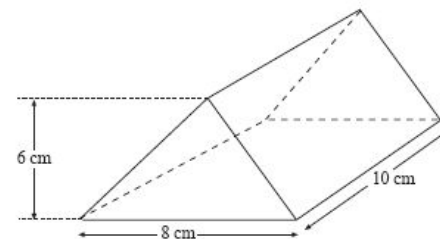

6. Calculate the volume and surface area of this triangular based prism.

7. Calculate the volume and surface area of these two prisms:

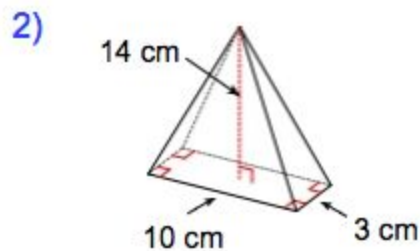
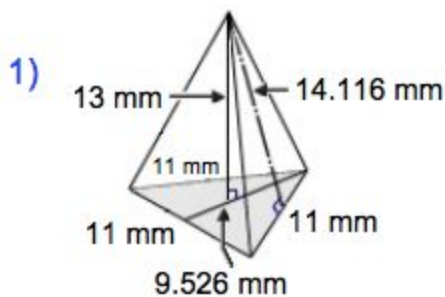

8. Find the volume of a cube, given that its surface area is 384 cm^2 .
9. Find the surface area of a cube, given that its volume is 512 cm^3
10. Find the volume of a sphere, given that its surface area is 600 cm^2 , rounding your answer to 3 significant figures.
11. Find the surface area of a sphere, given that its volume is 540 cm^3 , rounding your answer to 3 significant figures.
12. Find the area of the floor and the amount of glass used to build the latest addition to the entrance of the Louvre, the world famous museum in Paris, France. Its base measures 116 ft long.



Part 2 – Review - Extension Problems

1. Forty-two cubes with 2 cm edges are glued together to form a rectangular prism. If the area of the base is 24 cm and the width of the base is greater than 2 cm, what is the height of the prism?
2. Daisy bought herself a vase to fill with potpourri for Christmas. If the vase has the dimensions as shown, how much potpourri will she need to fill the vase up to the top?
3. A business downtown keeps erasers in boxes with dimensions 24 cm x 28 cm x 13 cm. The erasers have dimensions 2 cm x 4 cm x 1 cm. One of the boxes is half full with erasers.
 - a. How much room is left in the box to put more erasers?
 - b. How many erasers can fit into the empty half of the box?

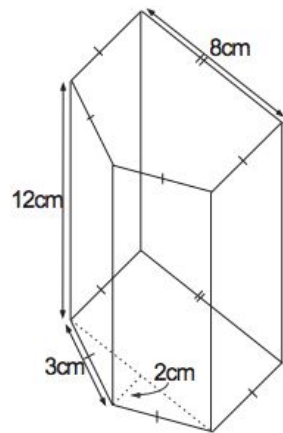

4. Calculate the amount of metal needed to make 8 cylindrical cans with a diameter of 6 cm and a height of 16 cm.

5. Find the smallest cylinder than can fit a cube of 1000 m^3 .

6. Dean is building a swimming pool in his backyard. The swimming pool will be 18 m long, 24 m wide, and 4.5 m deep. The pool is going to be tiled, with a tile size if 1 m^2 , and it will cost 15 cents per square meter.
 - a. What will it cost to tile the pool?
 - b. How much water can the pool hold?

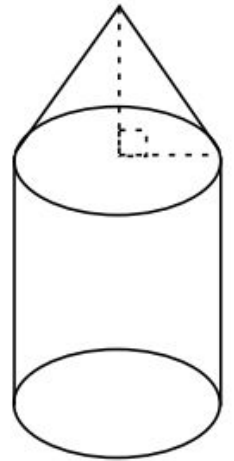

7. A small water bottle can hold 389.36 ml of water. Assuming for simplicity, the shape of a typical water bottle is a cylinder with a cone on top, as shown, with a radius of 5 cm. If the total height of the bottle is 6.37 cm, and the height of the cone is half the height of the cylinder, what is the height of the cylinder, and what is the height of the cone?

8. A new tablet is formed through attaching two hemispheres to the ends of a cylinder with a height of 610 mm and radius r . If the volume of the tablet is equal to the volume of a cone of height 189 cm and radius r , find the value of r in mm.

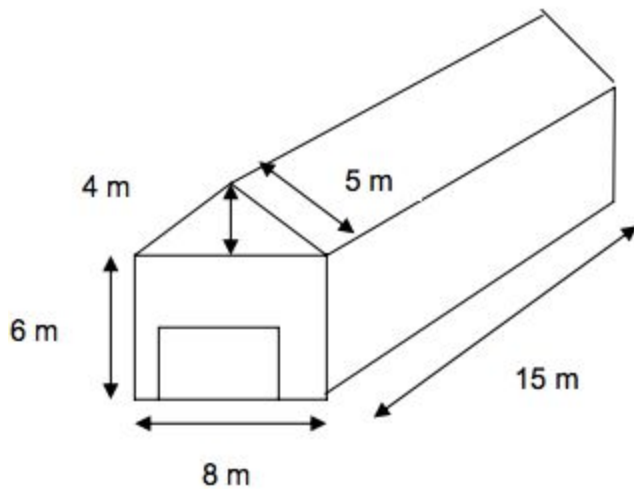

The door of the barn-house has dimensions of 5 m wide by 4 m tall.

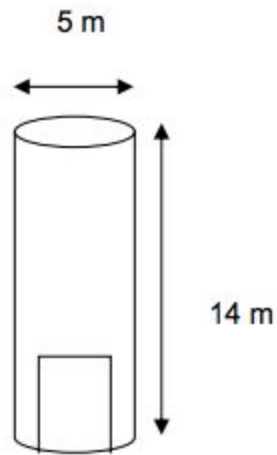

The door of the silo has dimensions of 3 m wide by 5 m tall.

9. Old McDonald wants to paint his barn-house and silo. The entire barn-house and silo will be painted red, EXCEPT for the two doors – those will be painted white. Be aware that it is not possible to paint the bottom of the barn-house and silo.
- What is the area of the barn-house door that will be painted white?
 - What is the area of the barn-house that will be painted red?
 - What is the area of the silo door that needs to be painted white?
 - What is the area of the silo that will be painted red?
 - What is the total surface area that will be painted red? What would the answer be in squared feet?
 - What is the total surface area that will be painted white? What would the answer be in squared feet?
 - If one can of paint will cover a total of 1000 ft²;
 - How many cans of white paint will Old McDonald need to buy?
 - How many cans of red paint will Old McDonald need to buy?
 - How many paint cans will Old McDonald need to buy in total?