

# Math SL EXPLORATION LAB 3

## Applications Geometric Series - Annuities

### PART A - The BASICS (*Cirrito 8.3.2, p268*)

- Here is an example showing how to analyze a FUTURE VALUE of an annuity type question, wherein you need to see how geometric series are involved
- Practice question  $\Rightarrow$  Mr. S is saving \$325 every month to help save for Ian's college expenses. The college investment fund that he sets up for Ian pays 6% p.a compounded monthly. If he has plans of contributing to this investment plan for 18 years, determine the FUTURE VALUE of this college fund.

#### **EXAMPLE 1** Representing the future value of an annuity earning compound interest as a series

- Hans plans to invest \$1000 at the end of each 6-month period in an annuity that earns 4.8%/a compounded semi-annually for the next 20 years. What will be the future value of his annuity?
- You plan to invest \$ $R$  at regular intervals in an annuity that earns  $i\%$  compounded at the end of each interval. What will be the future value,  $FV$ , of your annuity after  $n$  intervals?

#### Barbara's Solution

a)  $i = \frac{0.048}{2} = 0.024$

$n = 20 \times 2 = 40$

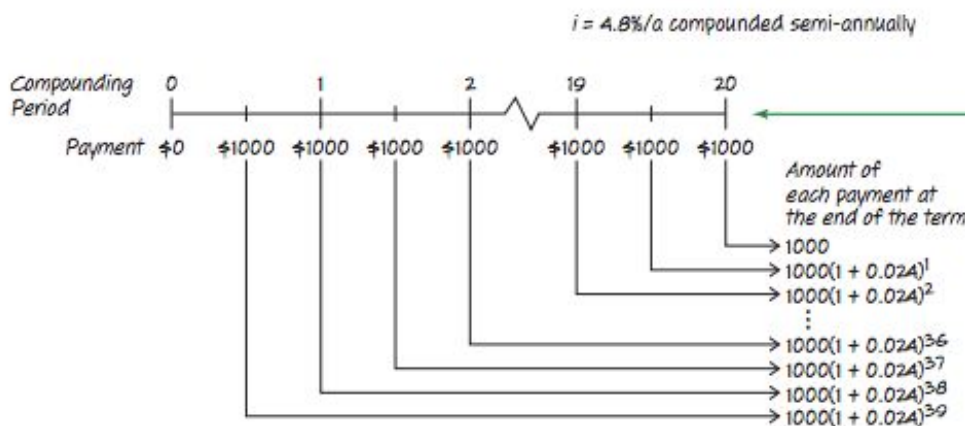

Since the interest is paid semi-annually, I calculated the interest rate per compounding period and the number of compounding periods.

I drew a timeline of the investments for each compounding period, and I represented the amount of each investment.

The last \$1000 investment earned no interest because it was deposited at the end of the term.

The first \$1000 investment earned interest over 39 periods. It didn't earn interest during the first compounding period because it was deposited at the end of that period.

# Math SL EXPLORATION LAB 3

3. Practice Questions  $\Rightarrow$  answer the 4 questions below

2. Calculate the future value of each annuity.

	Regular Payment	Rate of Compound Interest per Year	Compounding Period	Time
a)	\$100 per month	3.6%	monthly	50 years
b)	\$1500 per quarter	6.2%	quarterly	15 years
c)	\$500 every 6 months	5.6%	semi-annually	8 years
d)	\$4000 per year	4.5%	annually	10 years

3. Lois invests \$650 every 6 months at 4.6%/a compounded semi-annually for 25 years. How much interest will she earn after the 25th year?

4. More Practice Questions .....

5. Calculate the future value of each annuity.

**K**

	Regular Payment	Rate of Compound Interest per Year	Compounding Period	Time
a)	\$1500 per year	6.3%	annually	10 years
b)	\$250 every 6 months	3.6%	semi-annually	3 years
c)	\$2400 per quarter	4.8%	quarterly	7 years
d)	\$25 per month	8%	monthly	35 years

6. Mike wants to invest money every month for 40 years. He would like to have

**A** \$1 000 000 at the end of the 40 years. For each investment option, how much does he need to invest each month?

- a) 10.2%/a compounded monthly
- b) 5.1%/a compounded monthly

# Math SL EXPLORATION LAB 3

5. Here is a second example showing how to analyze a PRESENT VALUE of an annuity type question, wherein you need to see how geometric series are involved

## EXAMPLE 1    Representing the present value of an annuity earning compound interest as a series

- a) How much would you need to invest now at 8.3%/a compounded annually to provide \$500 per year for the next 10 years?  
 b) How much would you need to invest now to provide  $n$  regular payments of  $\$R$  if the money is invested at a rate of  $i\%$  per compounding period?

### Tara's Solution

a)  $i = 8.3\%/a$  compounded annually

Compounding Period: 0, 1, 2, 3, 8, 9, 10  
 Payment: \$0, \$500, \$500, \$500, \$500, \$500, \$500  
 Present value of each payment:  
 $\frac{500}{(1 + 0.083)^1}$   
 $\frac{500}{(1 + 0.083)^2}$   
 $\frac{500}{(1 + 0.083)^3}$   
 $\vdots$   
 $\frac{500}{(1 + 0.083)^8}$   
 $\frac{500}{(1 + 0.083)^9}$   
 $\frac{500}{(1 + 0.083)^{10}}$

$PV = \frac{A}{(1 + i)^n}$   
 $PV_1 = \frac{500}{(1.083)}$   
 $PV_2 = \frac{500}{(1.083)^2}$   
 $PV_3 = \frac{500}{(1.083)^3}$

I drew a timeline showing the \$500 payments for the next 10 years.  
 I considered each payment separately and used the present-value formula to determine how much would need to be invested now to provide each \$500 payment.

# Math SL EXPLORATION LAB 3

## 6. Practice Questions

3. Calculate the present value of each annuity.

**K**

	Regular Payment	Rate of Compound Interest per Year	Compounding Period	Time
a)	\$5000 per year	7.2%	annually	5 years
b)	\$250 every 6 months	4.8%	semi-annually	12 years
c)	\$25.50 per week	5.2%	weekly	100 weeks
d)	\$48.50 per month	23.4%	monthly	$2\frac{1}{2}$ years

13. Leo invests \$50 000 at 11.2%/a compounded quarterly for his retirement. Leo's financial advisor tells him that he should take out a regular amount quarterly when he retires. If Leo has 20 years until he retires and wants to use the investment for recreation for the first 10 years of retirement, what is the maximum quarterly withdrawal he can make?
14. Charmaine calculates that she will require about \$2500 per month for the first 15 years of her retirement. If she has 25 years until she retires, how much should she invest each month at 9%/a compounded monthly for the next 25 years if she plans to withdraw \$2500 per month for the 15 years after that?

# Math SL EXPLORATION LAB 3

---

## PART B - The PROBLEMS

### 7. Saving for Retirement

Steve, Carol and Lisa get their first full-time jobs and talk about saving money for their retirement. They are each 22 years old and plan on working until they are 55.

Steve starts investing immediately and puts aside \$150 per month. Carol wants to enjoy life a bit and decides to start contributing when she turns 30. Lisa thinks that both her friends are starting too early and decides to wait until she is 42 before starting to save.

Assuming that Steve, Carol and Lisa are each earning 9% p.a. compounded monthly. Carol and Lisa want to accumulate the same amount as Steve upon their retirement. When they retire, Steve wants his investment to last 10 years, Carol wants hers to last 15 years and Lisa wants hers to last 20 years.

PROBLEM: How much will Steve, Carol and Lisa be able to withdraw monthly upon retirement? Work through the following 5 questions to help develop an answer to this problem.

- A. What strategies will you use to solve this problem? Justify your strategies.
- B. How much money will Steve have accumulated by the time he is 55? What assumptions are you making?
- C. How much will Lisa and Carol have to deposit each month to meet their goals?
- D. Whose investment plan is “the best”? Justify your answer.
- E. How much will each person be able to withdraw from their retirement fund (after the age of 55 of course) each month?
- F. EXTENSION: Let’s assume the same investment return (9% p.a. compounded monthly) over the life of your investment and let’s ignore the effect of inflation for now. You wish to retire and have monthly withdrawals from your retirement fund of \$4,000 per month. So outline a savings strategy that you can use to meet this condition. State any assumptions that you are making in designing your investment strategy.